

Life of Christ
from the gospel of
John

Lesson 11

Jesus is Arrested

John 18:1-14

Mission Arlington • Mission Metroplex Curriculum • 2010

Created for use with young, unchurched learners • Adaptable for all ages including adults

Life of Christ

Jesus is Arrested

John 18:1-14

Younger Verse

"It is better if one person dies for the people." John 18:14 (CEV)

Older Verse

This was the same Caiaphas who had told the Jewish leaders, "It is better if one person dies for the people." John 18:14 (CEV)

Bible Story

The following is a summary of the Bible story to help supplement your preparation. In your personal study time, use this summary as a guide, and make notes to help you remember your plans for the lesson. Please do **NOT** read to the children.

Teachers:

We jump ahead here in preparation for Easter. In Lesson 15 we return to John 4.

Do you have a place where you and your friends go a lot, a place where you like to spend time together? Or maybe you had a place like that years ago. Do you remember sharing special times there, and talking about special things? Jesus had just that kind of place, too. He and His disciples all knew about it — they went there a lot. This special place, where Jesus went many times with His disciples, was a garden, the Garden of Gethsemane. This garden was not like the gardens you may be used to. The Garden of Gethsemane wasn't a flower garden or a vegetable garden. This garden was full of olive trees.

After Jesus had a very special dinner with His disciples one Thursday evening, they walked through the city of Jerusalem. Judas was the only one not there because he was betraying Jesus. Jesus and His disciples left the city and crossed over the valley. Then, they arrived in that garden they had visited so many times. The garden was a familiar place where they were normally very comfortable. Tonight was different, though. Judas, who normally went with Jesus and His disciples to the garden, was on his way with Roman soldiers and the police. They came with burning torches and lanterns to light the way. They also came with weapons. Jesus knew everything that was going to happen to Him. Jesus had known from the beginning that Judas would betray Him¹ and He knew that Judas was on his way right now. Jesus did not wait for Judas and the soldiers to come and find Him. He did not run or hide. Jesus went to meet the angry crowd!

Even though Jesus already knew they were looking for Him, as He approached the soldiers and police, He asked them who they were looking for. They answered, "We are looking for Jesus, the one who is from Nazareth." Jesus answered them by saying, "I AM He!" When He said

¹ Jn 6:64, 70-71

Lesson Goals

Realize that Jesus is God.
Learn to follow Jesus' example. It is always okay to do what is right, even if it is difficult.
See that Jesus died for everyone.

² Ex 3:13-15

this, the men fell backwards like someone had pushed them. For these men, the name of God, “I AM,” was a very special name.² These men would not even speak this special remembrance name of God. Jesus did not just say this name, “I AM,” He said He was “I AM.” What does that mean? If “I AM” was an extra special name for God and Jesus claimed to be “I AM,” what did He mean? Jesus was saying that He is God! That’s why these men fell backwards. They were shocked that someone would claim to be God. They did not believe Jesus, even though He was telling the truth.

³ Jn 6:39, 17:12

The soldiers and officers had not come towards Jesus yet, so He asked again, “Who are you looking for?” And they answered, again, “Jesus, from Nazareth.” Jesus explained again, saying, “I AM He. If it is me you are looking for, let these other men go.” Jesus said this because He wanted His disciples to be kept safe. He knew that is what God wanted as well. He was not going to lose one of them, except for Judas who was in the process of betraying Him.³ As Jesus spoke, one of His disciples, Peter, pulled out his sword. He was ready to defend himself and Jesus. He swung it at a man named Malchus and cut off his right ear. Malchus was a slave who worked for the high-priest Caiaphas. Jesus did not encourage His disciples to continue fighting. Jesus told Peter to put away his sword. Jesus wanted Peter to know that this is what had to happen. This is why Jesus came.

⁴ Jn 11:47-52

The Roman soldiers and the officers arrested Jesus. They tied Him up. Then, they took Jesus to a man named Annas for questioning. Annas was related to the high-priest, Caiaphas. Annas was his father-in-law. Caiaphas, the high-priest, was the one who had said that it was better for one man to die so that the whole nation would not be lost.⁴ He was speaking about Jesus when he said it. Caiaphas did not understand the complete meaning of what he said, but it would come true. One man would die so that everyone could be saved. Jesus came to die so that whoever believes in Him will not be lost but will have eternal life. Jesus died for everyone. In order to receive eternal life, though, you must believe that He is “I AM,” sent to die in your place. And just like His disciples, once we belong to Him, we cannot be taken away from Him. Choose Him today!

Memory Verse Activities

Make crosses. Use craft sticks or foam and decorate with flowers, ribbon, etc. On a small, banner shaped piece of paper or foam, write the memory verse. Attach a ribbon hanger or a magnet to the back.

Prayer Time

Pray, thanking God for Jesus’ obedience, especially when it was difficult.

Preparing for Next Week—EASTER LESSONS

Lesson 12

Trials

(Peter’s Denial/Jesus is Questioned)

John 18:15-40

Preschool Lesson

Jesus is Arrested

Set up your Bible story area as a walled garden.
Sit in the midst of your preschoolers as you tell them this story.

Sing, “Jesus Loves Me.”

Late one night, after Jesus and His disciples had eaten a very special dinner together, they walked through the dark city streets. They arrived at the city wall and walked through. They walked down through a valley, away from the city. Then, they walked into a garden. This was not a garden of flowers or vegetable plants. This garden was full of trees. The trees were so big, that you couldn’t stretch your arms around them. These trees were tall, too. The trees in this garden were olive trees. Jesus and His followers had spent a lot of time together in this garden.

As Jesus walked into the garden, He knew what was going to happen. His disciple, Judas, was coming with soldiers and policemen to arrest Jesus. Jesus had not done anything wrong, but there were men who did not like Him. When Jesus talked about His Father, God, they became angrier. When He told them He was God, they decided they wanted Him dead!

Just as Jesus knew it would happen, Judas came to the garden, knowing that Jesus would be there with His followers. Judas came with the soldiers and policemen. They had torches and lanterns to light their way and were carrying weapons like swords and club. Jesus did not run away or try to hide. Jesus walked up to them and turned Himself in!

What Caiaphas, the church leader, had said was true. It was better for one man to die so that everyone else could be safe. But Caiaphas did not understand that Jesus let the soldiers arrest Him because He came to die. Jesus came to die for me and for you, for Judas and for Caiaphas. Jesus could have stopped the soldiers from taking Him. He is powerful and strong. But Jesus gave Himself—the soldiers did not have any power over Him!

Pray: Thank you, God, that Jesus did not run away from the soldiers who came to arrest Him. Thank you, Jesus, for dying in my place.

Activities

- Provide coloring pages and word puzzles that will enhance what you have taught today.
- Make an activity that allows students to choose from various implements, the ones used by the troops who came to arrest Jesus. (They came with lanterns, torches and weapons. Provide those pictures as well as others that weren't used.)
- Provide a word search of the characters from this lesson. (Jesus, Judas, Peter, Malchus, Annas, Caiaphas)
- Have available a map of Jerusalem, complete with Brook Kidron as well as the Garden of Gethsemane. Retrace Jesus' steps from the upper room, through Jerusalem, down to the garden.
- Bring a jar of olives to class. As students arrive, ask them to guess how many olives are in the jar. After the Bible lesson, award a prize to the student who is closest to the correct answer. You might even want to have a tasting of the olives as well.
- Make soldier's armor from paper bags. Cut a hole in the bottom and slit the front of the bag from top to bottom making an opening. Reenact the Bible lesson using all extras as soldiers.
- For older students: *Gethsemane* is derived from the Hebrew expression *Gat Shemen* which means *olive press*, a reference to the natural abundance of these trees and to the presence of oil presses in the region. This garden had many olive trees in the time of Jesus and continues to have many. Olive trees do not have rings, so determining their age is difficult. It is believed that no olive trees survived the destruction of Titus in 70 A.D., who was credited with razing all of the olive trees in Jerusalem. Nearly 2,000 years later, though, some of these trees may be shoots of the very ones Jesus visited His friends under!

You might even want to discuss the significance of the name Gethsemane. An olive press would have crushed the olive in order to draw out its oil. In a place meaning "olive press," Jesus experienced the pain of betrayal and arrest.

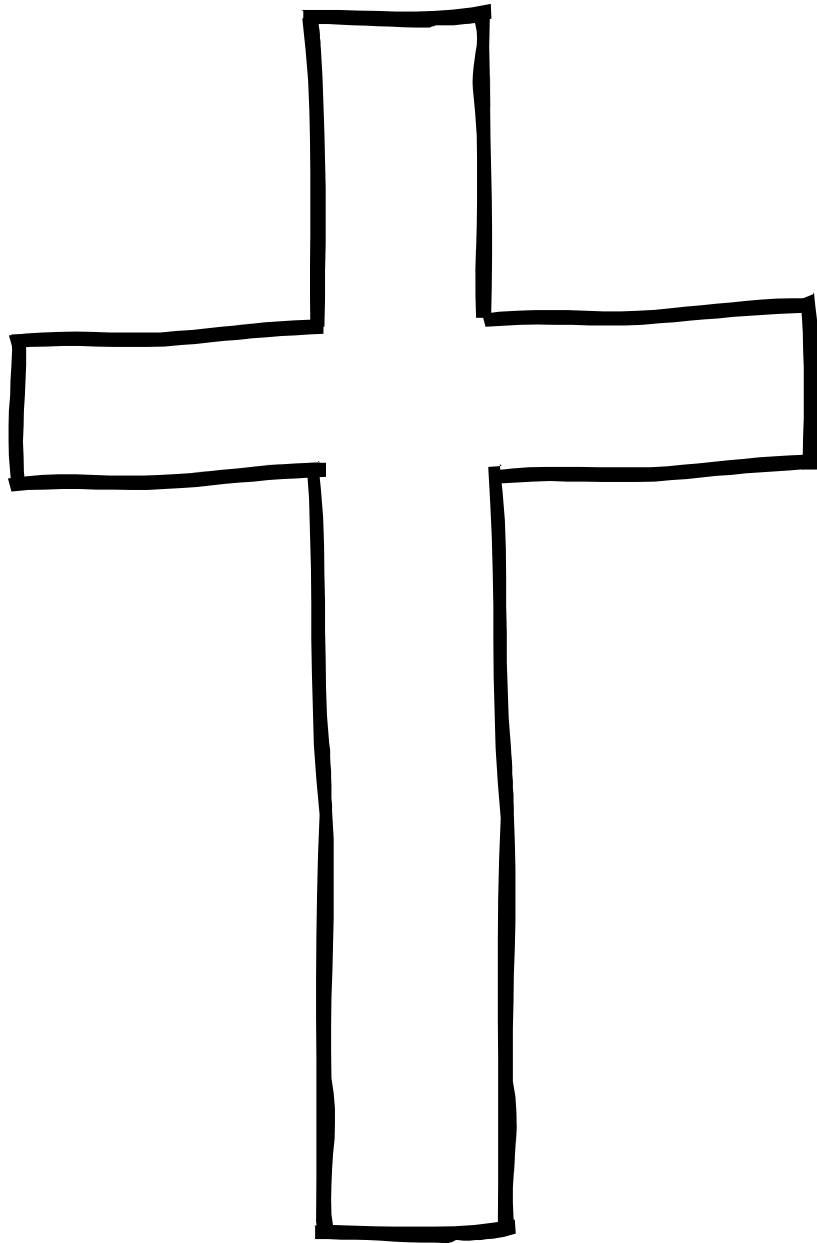

*"It is better if one person dies
for the people." John 18:14*

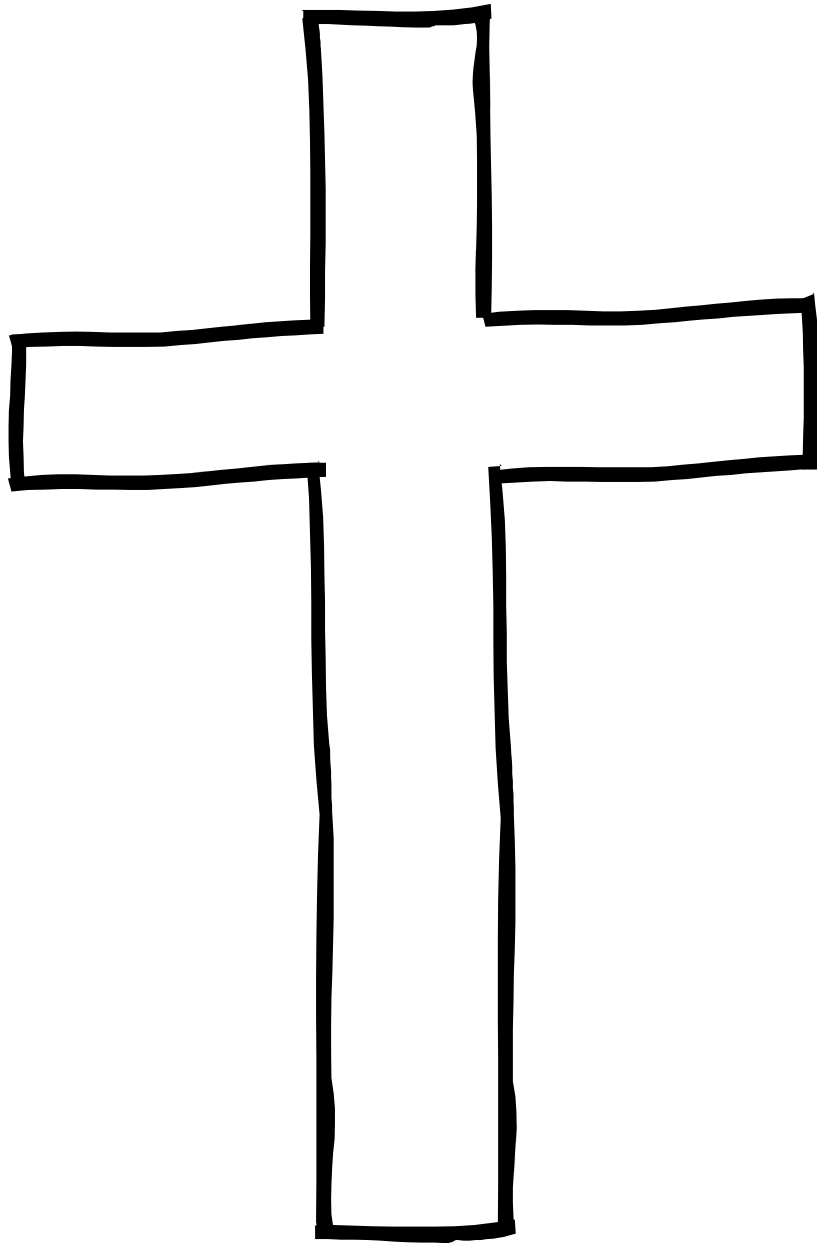

*This was the same Caiaphas who had told
the Jewish leaders, "It is better
if one person dies for the people." John 18:14*

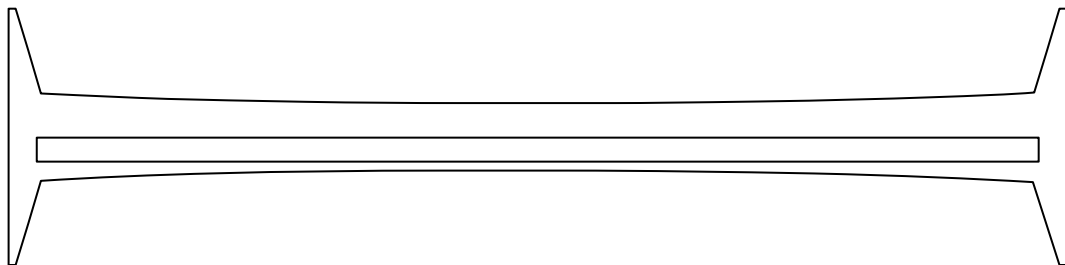
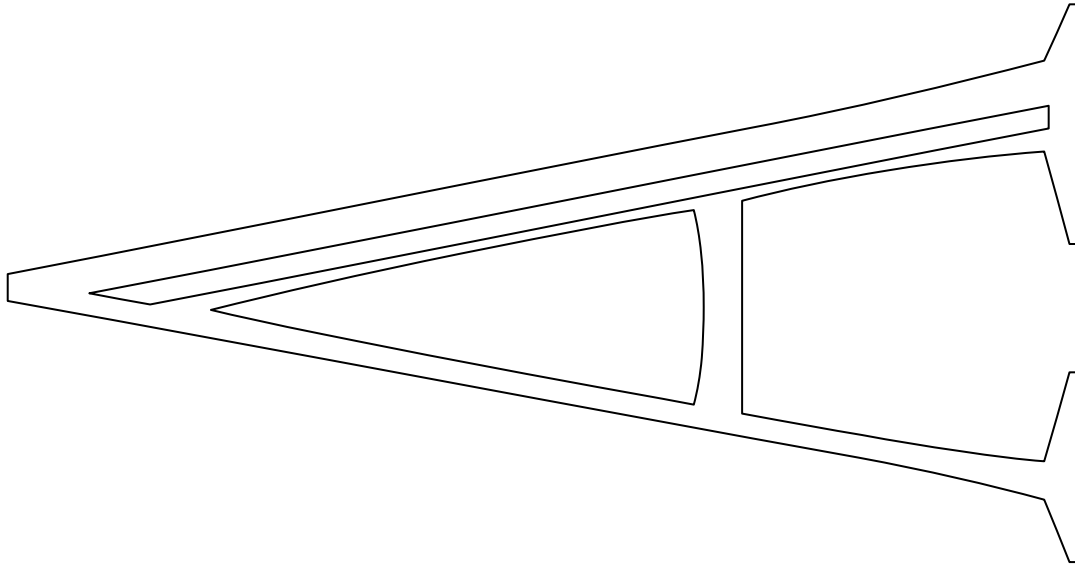
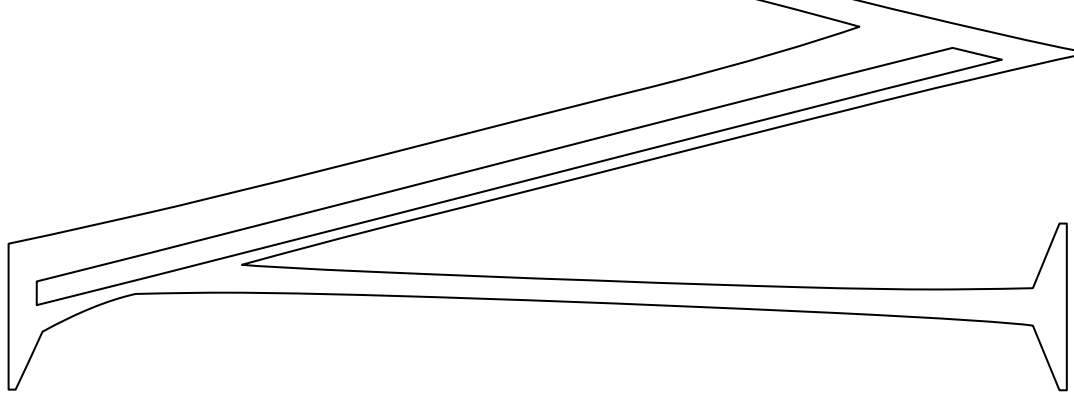
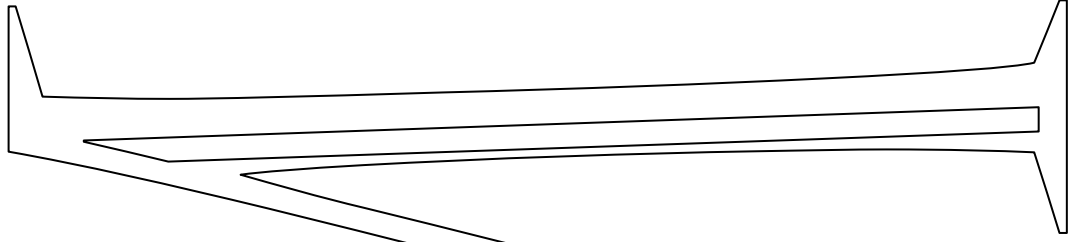

8

9

8

John 18:6

Word Search
.....
Jesus is Arrested

L F U M X A G S P E C I A L J
K I M K Q W N U B A I E R P U
T F V O A D I S C I P L E S D
M J M I I A R E G A A U C U H
H L K N N M P J X R X Q A B A
S G N D X G E H B I N E L V U
E E T M T Z W L Q A S C P N B
R T S W O R D S A C A R L E J
R H E A R R N I T S D Q A D C
A S R Y C I H W T E U X I R Y
J E R V H A S U R E J R C A T
I L A D E N A M E S H T E G H
O R O W S R D F X N I I P J K
X V X L D S R E I D L O S I W
M L R O M I P H E Q U T G T M

DINNER	JERUSALEM	GARDEN
GETHSEMANE	SPECIAL PLACE	DISCIPLES
JESUS	ARREST	JUDAS
SWORDS	SOLDIERS	TORCHES

Word Search

Jesus is Arrested

L	F	U	M	X	A	G	S	P	E	C	I	A	L	J
K	I	M	K	Q	W	N	U	B	A	I	E	R	P	U
T	F	V	O	A	D	I	S	C	I	P	L	E	S	D
M	J	M	I	I	A	R	E	G	A	A	U	C	U	H
H	L	K	N	N	M	P	J	X	R	X	Q	A	B	A
S	G	N	D	X	G	E	H	B	I	N	E	L	V	U
E	E	T	M	T	Z	W	L	Q	A	S	C	P	N	B
R	T	S	W	O	R	D	S	A	C	A	R	L	E	J
R	H	E	A	R	R	N	I	T	S	D	Q	A	D	C
A	S	R	Y	C	I	H	W	T	E	U	X	I	R	Y
J	E	R	V	H	A	S	U	R	E	J	R	C	A	T
I	L	A	D	E	N	A	M	E	S	H	T	E	G	H
O	R	O	W	S	R	D	F	X	N	I	I	P	J	K
X	V	X	L	D	S	R	E	I	D	L	O	S	I	W
M	L	R	O	M	I	P	H	E	Q	U	T	G	T	M

- | | | |
|------------|---------------|-----------|
| DINNER | JERUSALEM | GARDEN |
| GETHSEMANE | SPECIAL PLACE | DISCIPLES |
| JESUS | ARREST | JUDAS |
| SWORDS | SOLDIERS | TORCHES |

Word Search
.....
Jesus is Arrested

S	P	C	A	I	A	P	H	A	S
Y	U	E	L	B	L	A	F	A	C
J	E	S	U	S	I	X	Q	D	B
F	V	G	E	A	E	D	M	U	N
Z	Y	O	M	A	L	C	H	U	S
S	U	H	C	L	A	M	L	E	O
O	A	N	N	A	S	R	T	L	K
S	S	P	V	F	J	U	D	A	S
U	T	U	J	N	P	O	I	C	P
W	H	P	E	T	E	R	D	L	K

ANNAS
JUDAS

CAIAPHAS
MALCHUS

JESUS
PETER

Word Search
.....
Jesus is Arrested

S	P	C	A	I	A	P	H	A	S
Y	U	E	L	B	L	A	F	A	C
J	E	S	U	S	I	X	Q	D	B
F	V	G	E	A	E	D	M	U	N
Z	Y	O	M	A	L	C	H	U	S
S	U	H	C	L	A	M	L	E	O
O	A	N	N	A	S	R	T	L	K
S	S	P	V	F	J	U	D	A	S
U	T	U	J	N	P	O	I	C	P
W	H	P	E	T	E	R	D	L	K

ANNAS
JUDAS

CAIAPHAS
MALCHUS

JESUS
PETER